

 	<p>SAFETY INSTRUCTION X touch cETLus Rev.:0 Data: 30 07 2018</p>
<p>www.coel-is.com</p>	

Safety instruction Pendant cETLus

DESCRIPTION

The X Touch pendant control stations are built in 5 models.
 Inside the enclosures it is possible to insert switches, thermal protectors and a resistances as anti condensation heater.
 The pendant stations are intended to be used in industrial areas and in particular for Hazardous Locations.
 The enclosures are made in Aluminum UNI 8024.
 A protection cover of the keys in plastic material brand DUPONT type Zytel 80 G33 HS1 LNC10 with additive brand CLARIANT for antistatic function.
 It is included in all of X Touch types one OR (material HNBR-ambient temperature $-25/+100^{\circ}$) as shown in XTOUCH005US drawing date 14/03/2018 rev.0.

The X Touch series is built for **cETLus** in conformity with:

UL 1203 - Ed.5

CSA C22.2.30 - M1986
CSA C22.2.25

Marking ETLus:

Class I, Division 1, Groups A,B,C, D, T6 Tamb: $-20^{\circ}\text{C};+40^{\circ}\text{C}$.

Class II, Division 1, Group E, F and G, T6 Tamb: $-20^{\circ}\text{C};+40^{\circ}\text{C}$.

Class III, Division 1, T6 Tamb: $-20^{\circ}\text{C};+40^{\circ}\text{C}$.

Marking cETL:

Class I, Division 1, Groups B,C, D, T6 Tamb: $-20^{\circ}\text{C};+40^{\circ}\text{C}$.

Class II, Division 1, Group E, F and G, T6 Tamb: $-20^{\circ}\text{C};+40^{\circ}\text{C}$.

Class III, Division 1, T6 Tamb: $-20^{\circ}\text{C};+40^{\circ}\text{C}$.

JOINTS AND SAFETY ISSUES

All the references in relation to protection elements (lamination joints, thicknesses, dimensions, materials, ground screws, etc.) are specified on technical drawings attached (XTOUCH005US date 14/03/2018 rev.0).
 They are in conformity with UL 1203 Ed.5 - CSA C22.2.30 M1986 - CSA C22.2.25

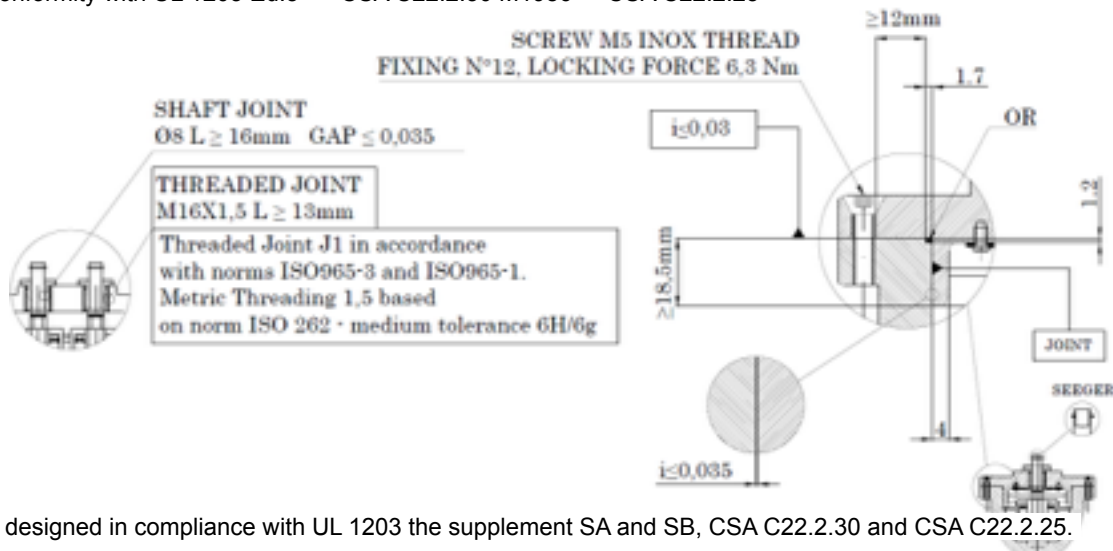

All joints was designed in compliance with UL 1203 the supplement SA and SB, CSA C22.2.30 and CSA C22.2.25.

Screws for closing the cover are of AISI 316 type as per ISO10642 quality A4 resistance class 70.

Screws are M 5x20 for cover and M 5x35 on additional cover for double body type - Yeld stress 450 N/mm².

ELECRICAL FEATURES

Inside built switches are of one type only suitable for VDC250 A0.27 Max or VAC 240V 3A Max 50/60 Hz.

The external supply cable must have minimum section of AWG18 contact and ground as well (cETLus)

The maximum allowed section is AWG14 (for US and Canada).

For US and Canada use cable type Extra hard usage.

For all the X touch pendant stations is possible to apply the following switches:

Auxiliary Device, Contact Block switches models DMKL01, DMKL10, DMKL11, DMLK02, DMKL20CC and DMKL20PR. Standard for safety: UL 508 and CSA C22.2 No. 14-13 Standard for Industrial Control Equipment.

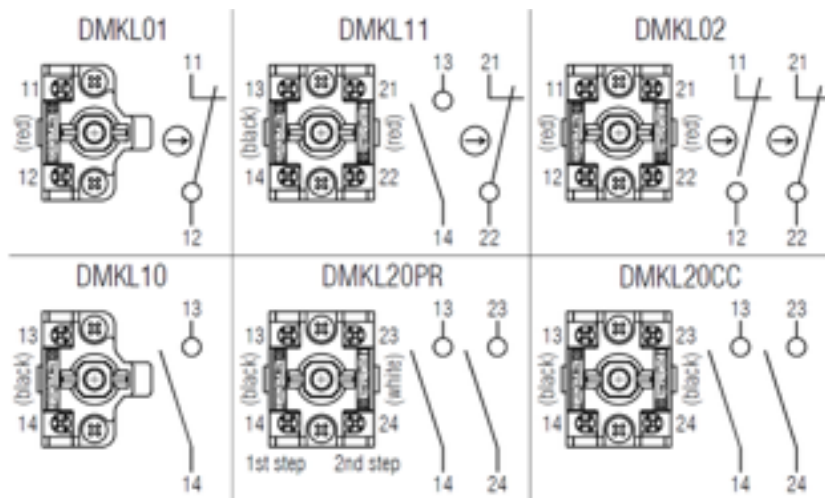

We could use all switch in random combination on the base of client request!

The Xtouch pedant station is identified by an item code, the last 3 numbers indicates the type of buttons intalled.

Item Code

		Manufacturer COEL MOTORI Fizzonasco (MILANO) ITALY www.coel-is.com				
		Serial number ID XXX				
Type TU	XX	XX	000	Year XXX	-20°C < Tamb < +40°C	5012265
U=250Vdc I= 0,27A Max		U=240Vac I= 3A Max		f = 50/60Hz		
Certified to CSA Std. C22.2 No. 39, CSA Std. C22.2 No. 25				Conforms to UL Std. 1203		
Class I, Division 1, Group B,C,D, T6			Class I, Division 1, Group A,B,C,D, T6			
Class II, Division 1, Group E,F,G, T6			Class II, Division 1, Group E,F,G, T6			
Class III, Division 1, T6			Class III, Division 1, T6			
WARNING/AVERTISSEMENT:						
"Do not open when energized"						
"Ne pas ouvrir lorsqu'il est excité"						
"Suitable only for indoor usage"						
"Seulement pour un usage intérieur approprié"						
*For replacement purposes, use _____ AWG Type EXTRA HARD USAGE power-supply cord only						
*Pour les besoins de remplacement, utiliser _____ type AWG UTILISATION EXTRA DURE cordon d'alimentation seulement						
"A seal shall be installed within 50 mm of the enclosure"						
"Un joint doit être installé à moins de 50 mm de l'enceinte"						
"Cover joints must be cleaned before replacing cover"						
*"Joints de couverture doivent être nettoyés avant de remplacer la couverture" (for canadian market only)						

CABLE ENTRY

X Touch stations are supplied with 1 cable entry as per drawings (XTOUCH005US date 14/03/2018 rev.0):
NPT 1/2' - 3/4' - 1' ANSI/ASME B1.20.01

Cylindrical M20x1,5 – M25x1,5 – M32x1,5 –, tolerance medium 6H/6g, in accordance with ISO 965-3 and ISO 965-1 and ANSI/ASME B1.13 M.

All the devices for cable entry (conduits, cable gland, adapters) must be certified with minimum certification level as per valid certification of the pendant station (class I, Div 1, Group ABCD, and class II, Div 1, Group EFG approved for UL1203, sealed).

Ambient temperature -20 / +40 °C.

Minimum number of threading as per UL 1203, CSA C22.2.30, CSA C22.2.25.

Effective threading must be 6 minimum.

For US version use cable in as per UL 1203 requirement and wiring as per NFPA70 art. 500 and subsequent articles and CSA 22.1 Sec.18 for Canada version.

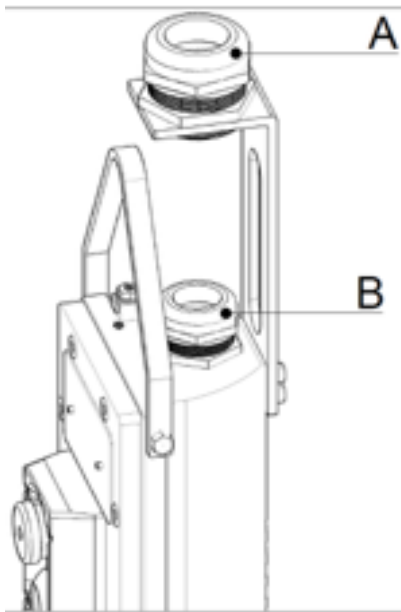

(Table cable entry)

Type	(A)	(B) not supplied
TU4	M25x1,5	M25x1,5 or NPT 3/4'
TU6	M32x1,5	M32x1,5 or NPT 1'
TU8	M32x1,5	M32x1,5 or NPT 1'
TU12	M32x1,5	M32x1,5 or NPT 1'
TU16	M32x1,5	M32x1,5 or NPT 1'

(Table cable entry Min-Max diameter fixing)

Type (A,B)	n.cable/AWG	Outside diameter (inches)
TU4 M25x1,5 or NPT 3/4'	8 / 18	0,39 - 0,67
TU6/TU12 M32x1,5 or NPT 1'	12 / 18	0,43 - 0,83
TU8/TU16 M32x1,5 or NPT 1'	16 / 18	0,43 - 0,83

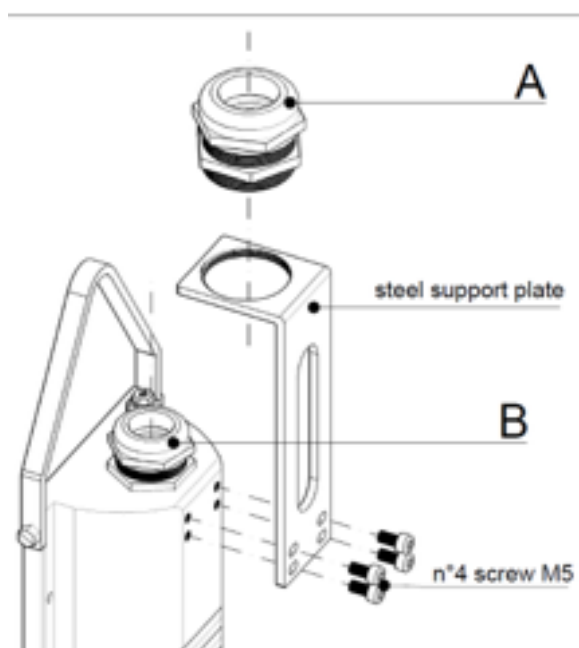

ASSEMBLY INSTRUCTION STEEL SUPPORT PLATE:

- Insert the cable gland (B) in the threaded hole placed on the upper part of the metal box and tight firmly
- Insert the cable gland (A) in the threaded hole placed in the upper part of the steel support plate
- Fix the steel support plate on the metal box with the four screws M5 (threaded fixing 6,3 Nm)
- Insert the electric cable (not supplied) through the two cable glands A&B
- In order to maintain the electric cable in its correct position, check and tight firmly the two cable glands A&B

Note : the selected cable gland B must have the same or higher protection class and marking of the xtouch, we suggest to check the tightening of cable gland B and in case of replacement to follow the cable gland producer instructions.

Note : cable tightening extra hard usage.

WARNING!

CHECK ALL THE WARNINGS ADVICES BEFORE INSTALLING THE ELECTRIC CABLE.
THE ELECTRIC CABLE MUST BE EXTRA HARD USAGE TYPE.

ALL THE CONNECTIONS MUST BE COMPLETED IN ACCORDANCE TO NFPA 70, CSA C22.1

FOR CLASS I DIV1 GROUP A,B,C,D AND CLASS II DIV1 GROUP E,F,G.

All the described information are also printed on a label applied to the housing of the pendant station as in the picture below.

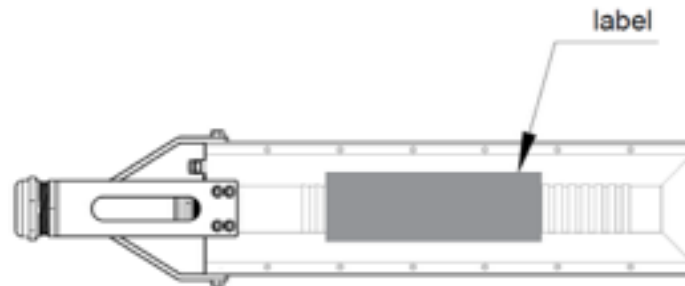

TECHNICAL FEATURES CABLE GLAND (A) :

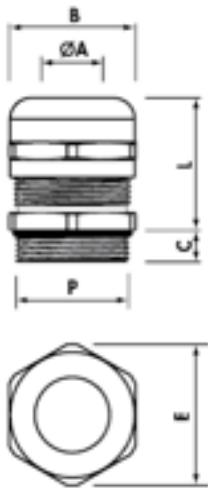

M 1,5 CEI EN 60423 CEI EN 50262

Tipo Ottone Nichelato	P	Foro Fissaggio (mm)	Ø A min-max (mm)	B Chiave (mm)	E (mm)	C (mm)	L min-max (mm)
2900.M25N	M25X1,5	25,5	10 -17	29	32	8,0	25-31
2900.M32N	M32X1,5	32,5	11 -21	36	40	9,0	27-34

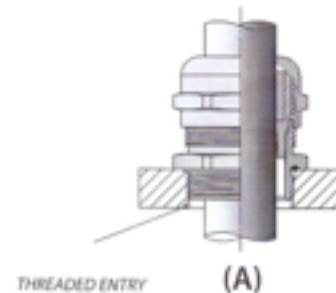
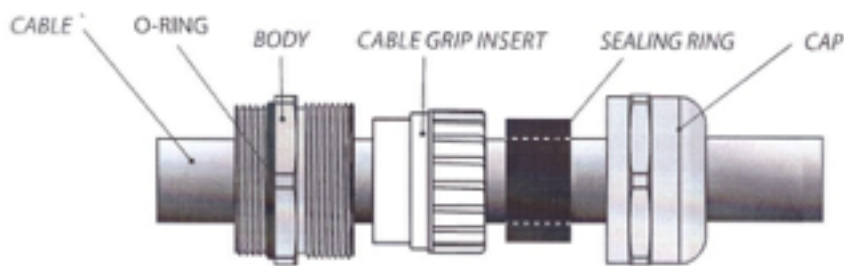

GENERAL INFORMATION:

- Material: Nickel plated Brass (CuZn40Pb3)
- Sealing ring: NEOPRENE®
- Cable grip insert: POLYAMIDE PA 6.6
- O-ring: NITRILE 70 sh A
- Protection: IP 68 - 5 bar / 30 min. (LIQUID TIGHT)
- Temperature range: - 25°C to +100°C

INSTALLATION INSTRUCTIONS:

- 1) Screw the cable gland into an appropriate threaded entry (A).
Do not over tighten.
- 2) Pass the cable through the cable gland to the required length.
- 3) Screw on the cap until the sealing ring is in full contact with the cable.
- 4) Torque up the gland and cap to the levels shown in the table overleaf.

REF.	THREAD	Nominal		PULL FORCE	IMPACT CATEGORY						
		mm	mm inches								
2900.M25N	2901.M25N	M25x1.5	10-17	10-17	0.39-0.67	8	71	15.9	35	11-17	6
2900.M32N	2901.M32N	M32x1.5	11-21	11-21	0.43-0.83	12	106	15.9	35	13-21	6

Ground terminals:

All the Xtouch pendant station models have two grounding terminals, the first is placed inside the metal housing (ref. dis. XTOUCH005US date 14/03/2018 rev.0) and the second one is placed in the external part. The ground symbol can not be removed. Both of them must be connected to wires having section minimum as the phase one.



MARKING and Nomenclature

All models cETLus are one type only and marked for both certifications as described

Type: TU (Means cETLus)

Number of contacts: 4 to 16

In the code indication for threading of cable gland is indicated as follows

NPT 3/4" : N1

NPT 1" : N2

M25x1.5: M1

M32x1.5: M2

000 : this code identify internal switch series (the code is sequential, example 001-002-003-.....)

Model type example: TU 8 M1 000

a detailed part of nameplate will show the cable entry type

WARNING

cETLus

a) "Do not open when energized" - "Ne pas ouvrir lorsqu'il est excité"

b) "Suitable only for indoor usage" - "Seulement pour un usage intérieur approprié"

c) "For replacement purposes, use _____ AWG Type EXTRA HARD USAGE power-supply cord only" - "Pour les besoins de remplacement, utiliser _____ type AWG "UTILISATION EXTRA DURE" cordon d'alimentation"

d) "A seal shall be installed within 50 mm of the enclosure" - "Un scellement doit être installé à l'intérieur de l'enceinte à une distance de 50 mm"

e) "Cover joints must be cleaned before replacing cover" - "Joints de couverture doivent être nettoyés avant de remplacer la couverture" (for Canadian market only)

Name plate is made of steel and placed on the station as described in the picture

In case of double body type, it will be on the right one.





SINGLE BODY TYPE INSTALLATION INSTRUCTIONS

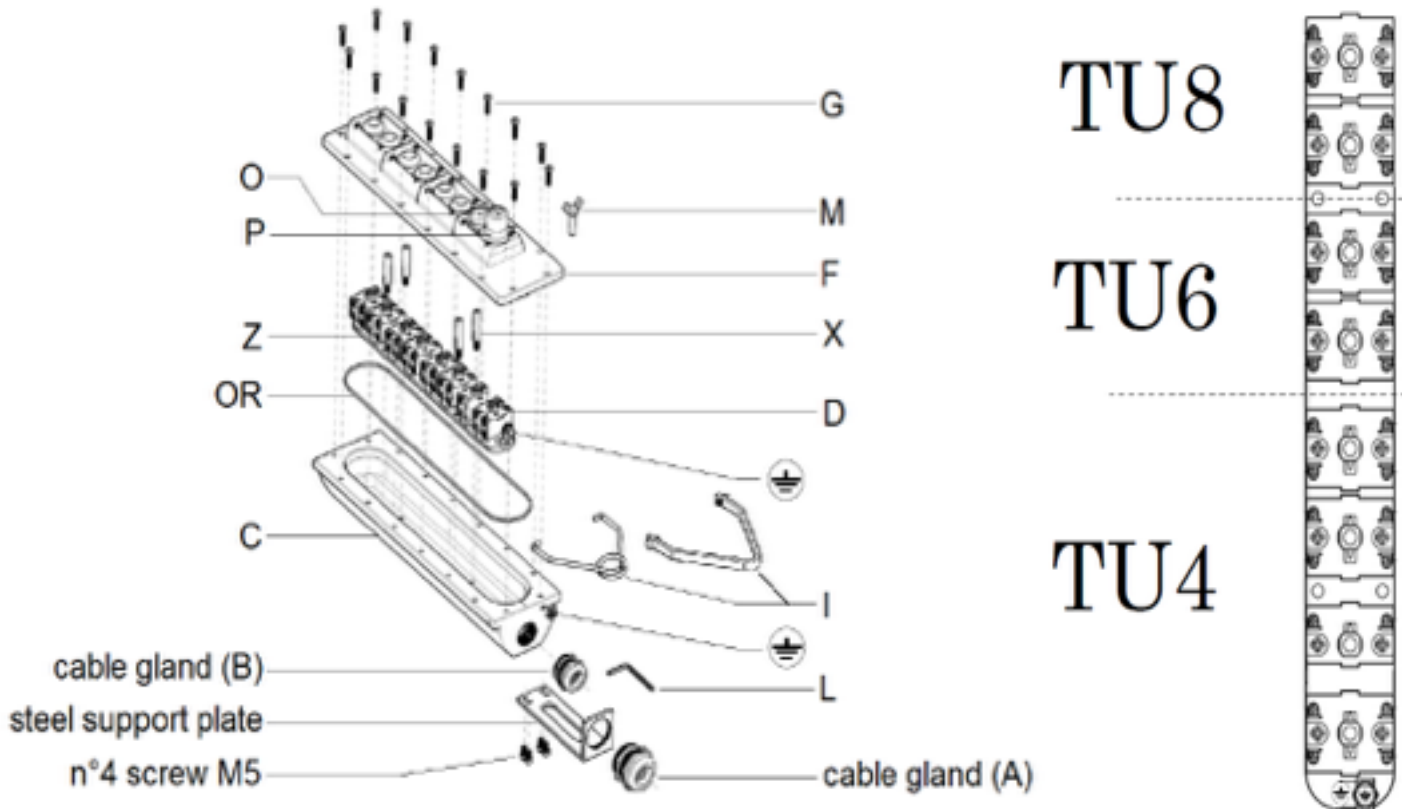

INSTALLATION

- 1) Open the covers F using the screws M
- 2) Unscrew the X pins using the key L supplied with the pendant station
- 3) Extract the switches layer Z
- 4) Following the instructions at the point " ASSEMBLY INSTRUCTION STEEL SUPPORT PLATE"
- 5) Connect the wires to the switches D. Locking force of screws is 1Nm.
- 6) Lock the switches layer Z to the base using the pins X. Locking force is 4,5 Nm.
- 7) Close the terminal box F
- 8) Fix the screws G with a torque value of 6,3Nm
- 9) Assemble the holding hook I on the base C
- 10) Connect the external ground terminal
- 11) Fix the steel holding cable to the holding hook

Notes: for wiring of cETLus versions follow the NFPA70 art. 500 and subsequent articles. For Canada version CSA 22.1 Sec.18. Cord-connected equipment employing a packing gland requiring dismantling during cord replacement shall be marked or provided with instructions regarding its installation and replacement."

- Key P is a double step key for power on and start on operation
- Emergency bottom O to be manually reactivated in case of use

The holding cable must have a length of 5cm shorter than the power supply cable in order to prevent the cable stress. The weight of the pendant station must be hold by the steel holding cable only.

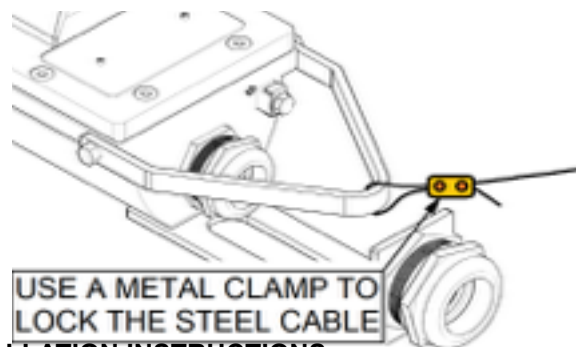

DOUBLE BODY TYPE INSTALLATION INSTRUCTIONS

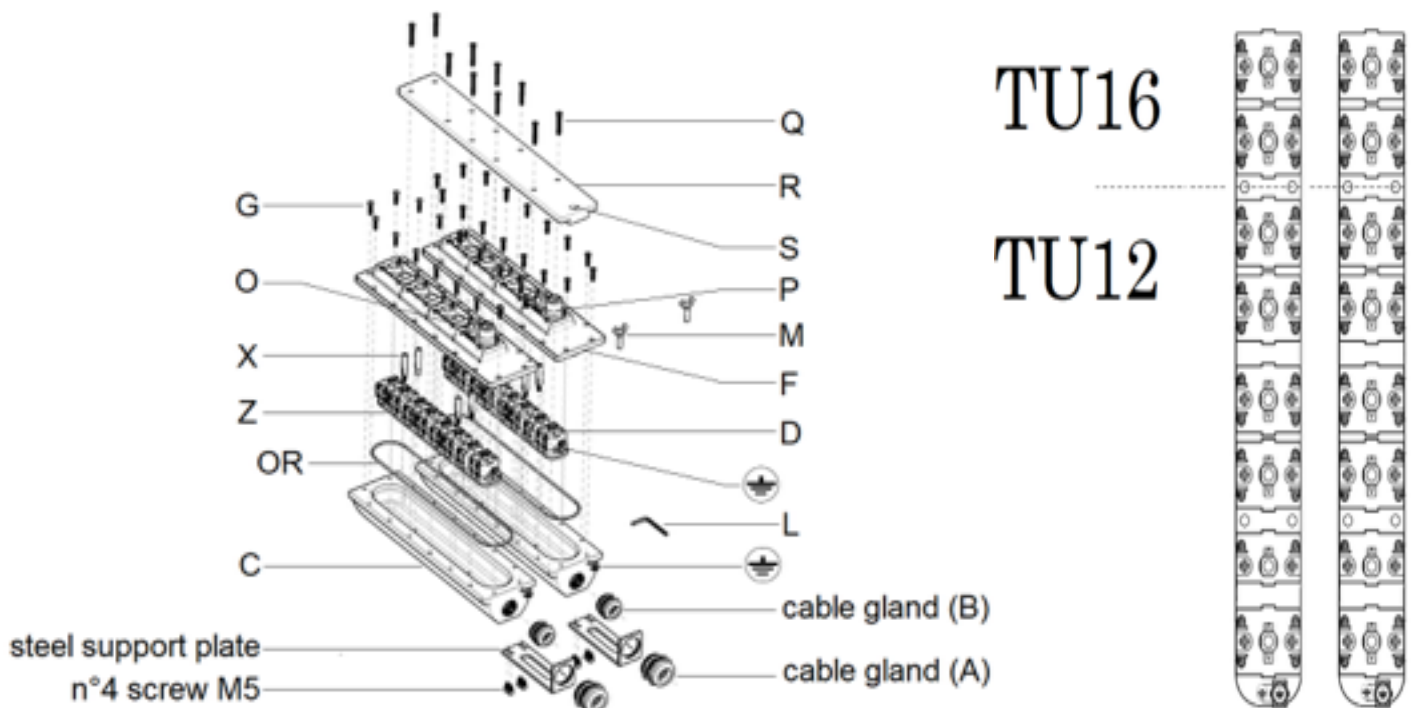

INSTALLATION

- 1) Unscrew the screws **Q** and remove the junction plate **R**
- 2) Open the covers **F** using the screws **M**
- 3) Unscrew the **X** pins using the key **L** supplied with the pendant station
- 4) Extract the switches layer **Z**
- 5) Following the instructions at the point “ **ASSEMBLY INSTRUCTION STEEL SUPPORT PLATE**”
- 6) Connect the wires to the switches **D**. Locking force of screws is 1Nm.
- 7) Lock the switches layer **Z** to the base using the pins **X**. locking force is 4,5 Nm.
- 8) Close the terminal boxes **F** and fix the screws **G** with a torque value of 6,3Nm and apply the plate **R**
- 9) Place the plate **R** and tight the screws **Q** with a torque value of 6,3Nm
- 10) Connect the external ground terminal
- 11) Fix the steel holding cable into the holding hole **S** drilled on **R** plate.

Notes: for wiring of cETLus versions follow the NFPA70 art. 500 and subsequent articles. For Canada version CSA 22.1 Sec.18. Cord-connected equipment employing a packing gland requiring dismantling during cord replacement shall be marked or provided with instructions regarding its installation and replacement.”

- Key **P** is a double step key for power on and start on operation
- Emergency bottom **O** to be manually reactivated in case of use

-Base Xtouch (**C**).

The holding cable must have a length of 5cm shorter than the power supply cable in order to prevent the cable stress
The weight of the pendant station must be hold by the steel holding cable only.

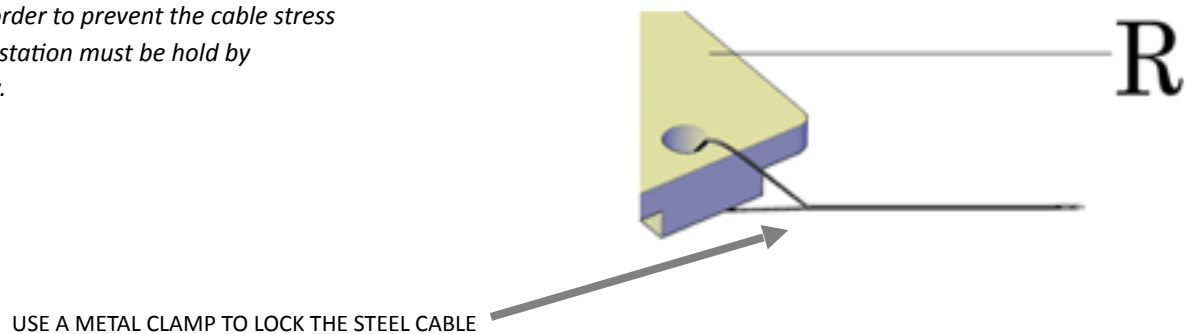

Cord replacement installation and replacement with packing gland installed:

- 1 – Remove the old packing
- 3 – Clean cable section
- 3 – Install new rings, one at time
- 4 – Press rings in the bottom box
- 5 – Re install cable and cable gland

ASSISTANCE

In case of product failure it must be returned to factory for inspection.

Flame joints are not intended to be repaired.

CLEANING

Clean the pendant station every day after usage with an anti static cloth in order to remove dust from the surface

ADDITIONAL NOTES

cETLus version is suitable for indoor usage only.
XTouch pendant stations are supplied painted with an epoxy paint layer between 70 and 100um.

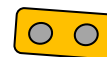

cETLus versions must be installed with a joint having a sealing within 50mm from threaded junction.
Paint must be conductive.

A product of COEL Motori s.r.l
Via Campania 36/40 - Fizzonasco di Pieve Emanuele, Milano, Italy
Tel +39 02 90420039 – Fax +39(0)290420747
www.coel-is.com