



VIS STANDARD BRAKES - OPERATING MANUAL

Introduction:

These safety instructions refer to the installation, operation and maintenance of the VIS STANDARD brakes.

The VIS standard brakes are negative spring applied brakes ready to be assembled to IEC B5 motors frames 71 to 225.

Declaration of Incorporation VIS STANDARD brakes

(in accordance with Annex II, part 1, Section B of Machinery Directive 2006/42/EC)

We hereby declare that the products below comply with the essential health and safety requirements specified in Annex I of Machinery Directive 2006/42/EC:

Annex I General Principles, Annex I Sections 1.1.2, 1.1.3, 1.1.5, 1.3.2, 1.5.1

The partly completed machinery must not be put into service until the final machinery into which it is to be incorporated has been declared in conformity with the provisions of Machinery Directive 2006/42/EC. The relevant technical documentation required for the partly completed machinery has been compiled in accordance with Annex VII, part B of Machinery Directive 2006/42/EC. The manufacturer undertakes to submit an electronic copy of the relevant technical documentation compiled for the partly completed machinery if reasonably requested by national authorities.

Manufacturer's liability

The manufacturer will not assume any responsibility for damage caused by failure to use the products in accordance with their intended use or by failure to observe safety information and other instructions provided in this manual. The information in this manual was correct and up-to-date before going to print. The information contained herein shall not entitle users to raise claims with respect to components purchased at an earlier date.

Mounting the brake module to the motor

Mount the brake module in a vertical position with the motor shaft pointing vertically upwards. Mount the brake module to the motor by slipping it onto the brake shaft until it makes contact with the motor flange. Ensure that the brake is parallel to the motor shaft and that a form-fit connection is established between the brake shaft and the flanges.

The brake shaft and ball bearing must not be exposed to any axial shocks.

Attention!

The tightening torque specified for the mounting screws must be strictly observed (see UNI EN 15048-1:2007). Tighten the mounting screws evenly in several steps.

Installation hand release “RS”

The VIS STANDARD brakes can be supplied with optional screw release system “RS”.

In order to release the brake use the following operating instructions:

- Remove the plastic tap of the 2 holes on the brake (left and right) prepared for release blocks
- Apply the 2 release blocks screwing the external bolt “A” to its threading end
- Release the brake screwing the internal screws “B”

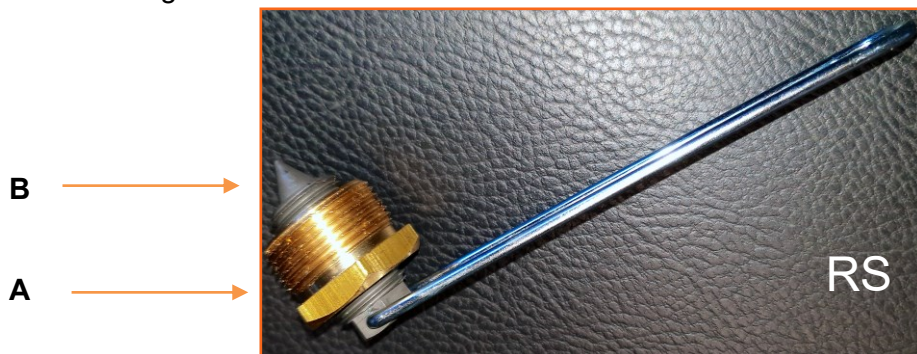

System release lever

This system allows to rotate the shaft manually in the absence of power. Once lever is actuated, the disc is free to rotate; when the lever is put to the original position, the brake returns to lock state.

It consists of an operating lever that acts on two pivots release positioned on two opposite sides of the housing of the brake. The lever is made of stainless steel, while the pins of unlocking steel which rotates on a bearing bush made of brass.

VIS STANDARD brakes can be supplied with (or ready for) hand release lever for the brake.

It allows the shaft to rotate even when the power is off. Pulling the hand release, when the end of the stroke is reached you have to increase the strain slightly until the shaft is released. Do not apply excessive force to the hand release lever. Releasing force on the mechanism, the brake automatically returns to the fail safe position.

When the brake is fitted with a manual brake release lever it must be installed so as to avoid any accidental activation of the release unit.

When the brake is ready for hand release lever [fig.3], on the brake case there are two opposite housing for release device covered by two screw plugs (N.1). To install the levers, before removing the screw plugs then screwing the release hinges (N.1) through the hexagonal nut.

[fig.3]

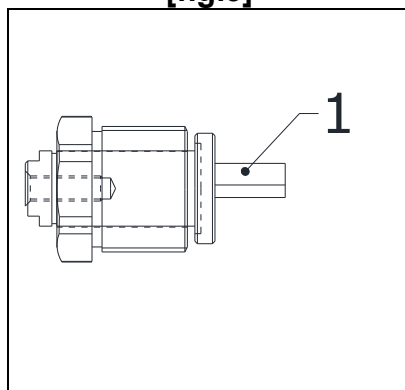

HAND RELEASE:

Drawing A - Output side release

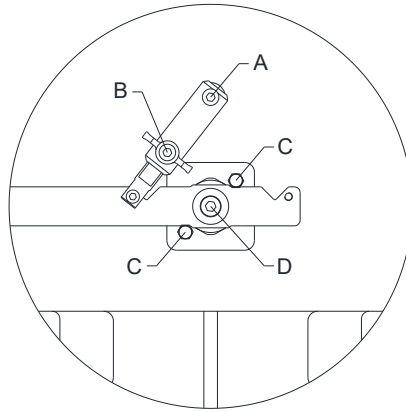

Drawing B - Input side release

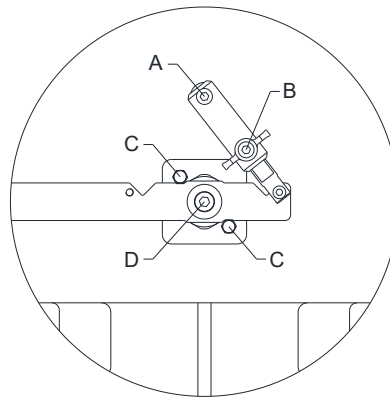

- 1-Assemble hand release and fix the screws D
- 2-Fix A type screw and position C screws
- 3-Release screws B
- 4-Release manually the brake operating on the lever
- 5-Fix B screws

Electrical connection

The following checks must be carried out when connecting the brake:

- Check that the connecting cables are suitable for the intended use and for the voltage and amperage of the brake.
- Check that the connecting cables are secured with screws, clamps or other suitable fixtures to avoid interruptions in the power supply.
- Check that the connecting cables are long enough for the intended use and that suitable torsion, strain and shear relief features as well as bending protections are provided.
- Check that no foreign matter, dirt or humidity is trapped inside the terminal box.

- Check that unused cable entries and the terminal box are suitably sealed to ensure compliance with the protection class requirements to EN 60529.

STANDARD CONNECTION (frame 71 to 160)*

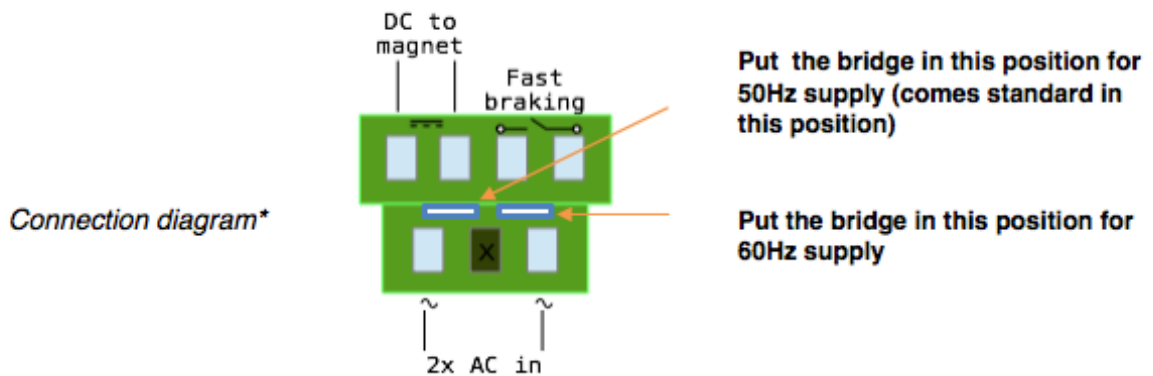

*The VIS standard series is supplied with a special rectifier suitable for AC 220 to 500 with fixed DC output. Move the frequency bridge in the right position before connecting the brake. Rectifiers come from factory with ridge connected for 50Hz supply.

CONNECTION WITHOUT RECTIFIER (on request)

In case of single voltage supply without rectifier, the brakes supply are supplied with loosen identified cables into the terminal box.

In case of PTO or any other auxiliary devices requirement, the supply terminals are loosen and identified into the terminal box

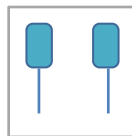

STANDARD CONNECTION WITH RECTIFIER FIXED VOLTAGE (frame 180 to 225)

In case of single voltage supply with rectifier the brakes supply are supplied with la terminal board and a rectifier inside the terminal box

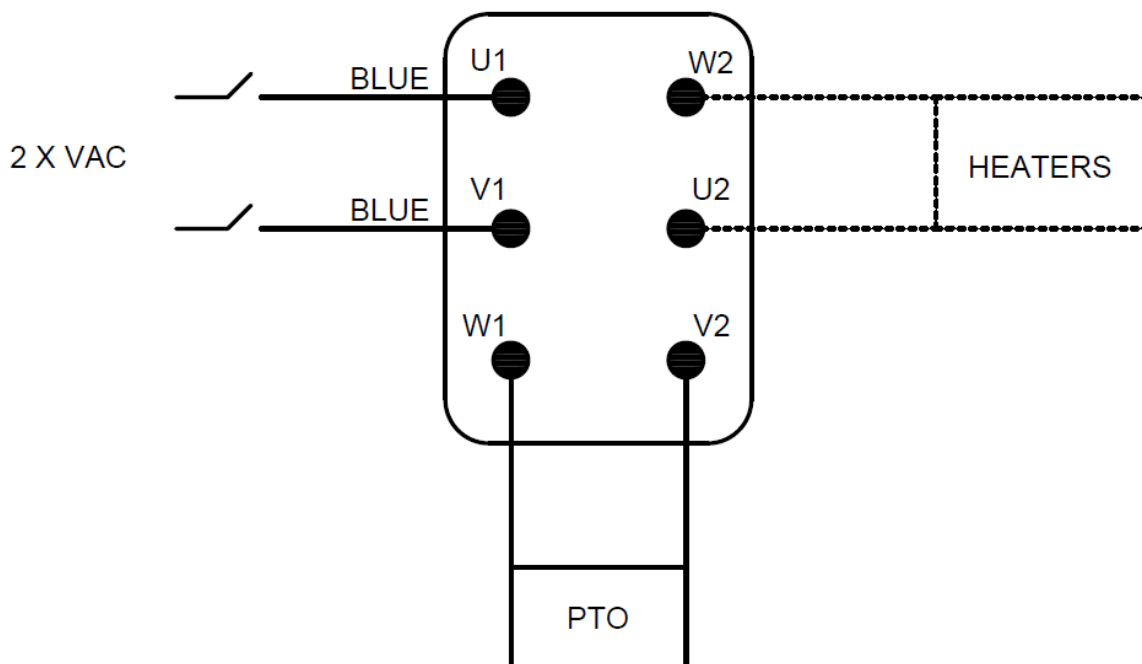

Nameplate Example

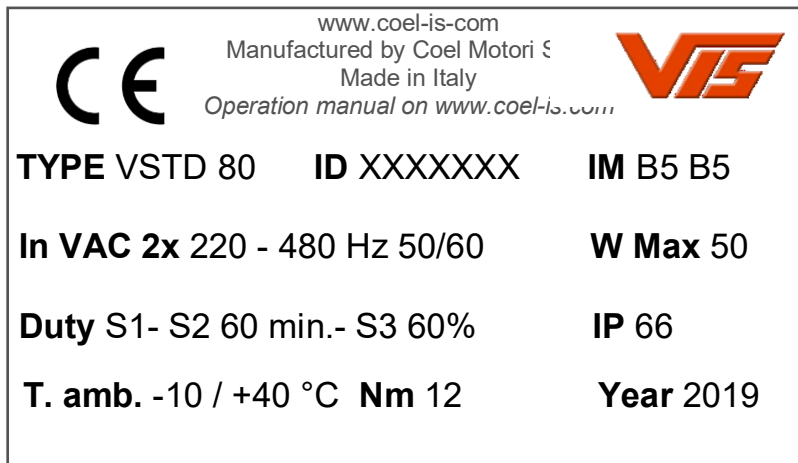

Type: Brake frame

ID: Lot number

IM: Input and output IEC flange and shaft

In VAC 2x: Input voltage range to the rectifier

W Max: Maximum power consumption to the rectifier

Duty: Designed duty

IP: protection level

T.amb.: Allowed ambient temperature

Nm: Nominal brake torque + / - 15%

Year: year of construction

Caution!

The brake module surface temperature may rise to over 100°C. Heat-sensitive parts such as conventional cables or electronic components must not be fixed to or be in contact with these surfaces. If necessary, suitable protections and hand guards must be installed to avoid accidental contact with hot surfaces!

Maintenance

Checks and service

The spring-applied single-disc brake module does not require any particular maintenance except that the air gap and the degree of wear of the friction disc must be measured at regular intervals. For this purpose, the brake must be released electromagnetically (while the motor is shut down) to allow the air gap 's' between the armature and friction disc to be measured through the threaded bore by means of a feeler gauge. The air gap can only be measured after having removed the cover or – when using brakes with hand release – after having removed the screws of the hand release. If the maximum air gap max of 1mm is reached, the friction disc must be replaced to maintain the functional reliability and safety of the brake. When replacing the friction disc, check the friction surfaces of the armature and flange. It is not possible to perform adjustments (air gap adjustments) to compensate for wear. The ball bearings are factory-lubricated with grease for a maximum service period of 3 years. If the ball bearings (accessories) needs to be replaced, make sure to use bearings of the same type or of identical design. The sealing rings do not require any maintenance. However, they should be replaced every time the brake module is opened. For detailed instructions regarding brake disc replacement please contact us.

Intended use

The brakes described in these operating instructions are intended to be assembled with machines, in particular electric motors, for use on industrial plant. Operation in potentially explosive or firedamp atmospheres is not allowed. The brakes must be used in accordance with the operating requirements detailed in this manual. The rated power limits specified herein must not be exceeded.

General safety information

Brake modules fitted to motors feature hazardous live components and rotating parts and may exhibit hot surfaces. Any work associated with the transport, connection, start-up and periodical maintenance of the brakes must be carried out by authorized and suitably qualified personnel (in accordance IEC 364). Failure to observe safety, operating and maintenance instructions may cause serious personal injury and severe damage to the equipment. Whenever special measures are required in accordance with the instructions contained herein, such measures should be agreed with the brake manufacturer before the machinery into which the brake is to be incorporated is set up. Accident prevention regulations applying to the specific field of application of the brake must be strictly observed. The brakes described in this manual are not designed for use as "safety brakes". This means that torque reductions caused by factors beyond the user's control cannot be excluded.

Date: 17/01/2025

Managing director: MORENO MOZZATI

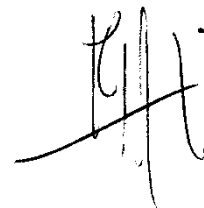

VIS is a product of Coel Motori S.r.l. - Any data or information in this document is not binding and can be modified in any moment without notice
www.coel-is.com